

ICET051E

ELECTRIC DIRECT STEAM COMBI OVEN
5 X 1/1 GN
5 X 600 X 400

ASSISTED COOKING
 MANUAL ELECTRONIC CONTROLS

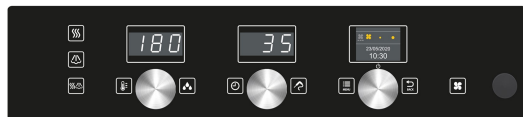

ELECTRONICALLY CONTROLLED

Each setting is easy and fast, thanks to the new browser display. The three knobs make manual use of the oven easy and intuitive, creating a same results as a mechanical oven.



COOKING PROGRAMS



CORE PROBE (OPTIONAL)



2 SPEED FAN



CLIMA



ECOSPEED



ECOVAPOR



AUTOMATIC WASHING



ECO WASH

TECHNICAL DATA

| | | | | | |
|-------------------------|----------|-------------------------------|-------------------------------------|-----------|-----------|
| Capacity | GN EN | 5 x 1/1 GN 5 x (600 x 400) | Gas versions nominal heating output | kW / kcal | - / - |
| Distance between layers | mm | 70 | Chamber heating output | kW / kcal | 7 / - |
| Meals - Croissants | n° | 30 / 80 - 60 / 80 | Steam heating output | kW / kcal | - / - |
| External dimensions | mm | 777 x 729 x 777 h | Fan power | kW | 0,2 |
| Packing dimensions | mm | 910 x 865 x 900 h | Power supply voltage | V | 3N-AC 400 |
| Weight - Net / Gross | kg | 74 / 85 | Frequency | Hz | 50 |
| Total electric power | kW | 7,25 | Consumption | Amp | 11 |

Special voltages and frequencies on request.

ICET051E

COOKING MODES

- AUTOMATIC WITH 95 TESTED AND STORED COOKING PROGRAMMES, INCLUDING PROGRAMMES FOR REHEATING ON THE PLATE OR IN THE PAN.
- PROGRAMMABLE WITH THE ABILITY TO STORE 99 COOKING PROGRAMMES IN AUTOMATIC SEQUENCE (UP TO 9 CYCLES), ASSIGNING A NAME AND DEDICATED ICON.
- MANUAL COOKING WITH THREE COOKING MODES AND INSTANT COOKING START: CONVECTION FROM 30°C TO 260°C, STEAM FROM 30°C TO 130°C, COMBINATION CONVECTION + STEAM FROM 30°C TO 260°C.
- CLIMA® - AUTOMATIC SYSTEM FOR MEASURING AND CONTROLLING THE HUMIDITY IN THE COOKING CHAMBER.
- RAPID SELECTION OF FAVOURITE PROGRAMS USING SCROLL & PUSH, WITH THE DEDICATED SCROLLER.

OPERATION

- LED HVS (HIGH VISIBILITY SYSTEM) ALPHANUMERIC DISPLAY TO DISPLAY THE TEMPERATURES, CLIMA, TIME AND CORE TEMPERATURE.
- 2.4-INCH (LCD - TFT) COLOUR DISPLAY FOR DISPLAYING YOUR FAVOURITE PROGRAMS, PRE-SET PROGRAMS, FAN, AUTOMATIC WASHING, MENUS AND SETTINGS.
- SCROLLER KNOB WITH SCROLL AND PUSH FUNCTION FOR CONFIRMING CHOICES.
- MANUAL PRE-HEATING.

CONTROL MECHANISMS

- AUTO REVERSE (AUTOMATIC REVERSE OF FAN ROTATION) FOR PERFECT COOKING UNIFORMITY.
- AUTOMATIC CHAMBER VENTING CONTROL.
- MANUAL HUMIDIFIER.
- EASY ACCESS TO PROGRAMMABLE USER PARAMETERS TO CUSTOMISE THE APPLIANCE THROUGH THE USER MENU.
- 2 FAN SPEEDS, THE REDUCED SPEED DECREASES HEATING POWER. FOR SPECIAL COOKING METHODS, YOU CAN USE AN INTERMITTENT SPEED.
- TEMPERATURE CONTROL AT THE PRODUCT CORE USING A PROBE WITH 4 DETECTION POINTS (CORE PROBE OPTIONAL).
- NEEDLE CORE PROBE Ø 1 MM, FOR VACUUM COOKING AND SMALL PIECES (OPTIONAL).
- USB CONNECTION TO DOWNLOAD HACCP DATA, UPDATE SOFTWARE AND LOAD/DOWNLOAD COOKING PROGRAMMES.
- PRE-CONFIGURED SN ENERGY OPTIMISATION SYSTEM (OPTIONAL).
- SERVICE PROGRAM: TESTING THE OPERATION OF THE ELECTRONIC BOARD - DISPLAY OF THE TEMPERATURE PROBES - COUNTER FOR OPERATING HOURS OF ALL PRIMARY FUNCTIONS FOR PROGRAMMED MAINTENANCE.
- SELF-DIAGNOSIS BEFORE STARTING TO USE THE EQUIPMENT, WITH DESCRIPTIVE AND AUDIBLE SIGNALLING OF ANY ANOMALIES.
- LED COOKING CHAMBER LIGHTING.
- ECOSPEED - BASED ON THE QUANTITY AND TYPE OF PRODUCT, THE OVEN OPTIMISES AND CONTROLS THE ENERGY OUTPUT, MAINTAINING THE BEST COOKING TEMPERATURE AND AVOIDING FLUCTUATIONS.
- ECOVAPOR - WITH THE ECOVAPOR SYSTEM, THERE IS A NET REDUCTION IN WATER AND ENERGY CONSUMPTION DUE TO THE AUTOMATIC CONTROLS OF THE STEAM SATURATION IN THE COOKING CHAMBER.

CONSTRUCTION

- PERFECTLY SMOOTH WATERTIGHT COOKING CHAMBER WITH ROUNDED EDGES.
- DOOR WITH DOUBLE TEMPERED GLASS WITH AIR CHAMBER AND INTERIOR HEAT-REFLECTING GLASS FOR LESS HEAT RADIATION TOWARDS THE OPERATOR AND GREATER EFFICIENCY.
- INTERNAL GLASS THAT FOLDS TO OPEN FOR EASY CLEANING.
- HANDLE WITH LEFT OR RIGHT HAND OPENING.
- ADJUSTABLE HINGE FOR OPTIMAL SEAL.
- DEFLECTOR THAT CAN BE OPENED FOR EASY FAN COMPARTMENT CLEANING.
- IPX3 PROTECTION AGAINST WATER SPLASHES.

ELECTRIC HEATING SYSTEM

- COOKING COMPARTMENT HEATING ELEMENTS OF ARMoured.

SAFETY FEATURES

- COOKING COMPARTMENT SAFETY THERMOSTAT.
- FAN MOTOR THERMIC PROTECTION.
- LACK OF WATER DISPLAYED ALARM.
- SELF-DIAGNOSIS AND FAULT DISPLAY.
- COMPONENT COOLING SYSTEM WITH OVERHEAT DISPLAY CONTROL.
- MECHANICAL DOOR SWITCH.

CLEANING AND MAINTENANCE

- AUTOMATIC CLEANING SYSTEM LCS (LIQUID CLEAN SYSTEM) (OPTIONAL), WITH BUILT-IN TANK AND AUTOMATIC DISPENSING (COMBICLEAN LIQUID CLEANSER IN 100% RECYCLABLE CARTRIDGES. SUPPLIED WITH 1 LIQUID CLEANSER CARTRIDGE CDL05 - 990 GR.).
- 7 AUTOMATIC CLEANING PROGRAMMES.
- MANUAL CLEANING SYSTEM WITH EXTERNAL HAND SHOWER (SHOWER OPTIONAL).

STANDARD EQUIPMENT

- THE UNIT IS READY TO BE RETROFITTED WITH THE FOLLOWING TENSIONS: 1N-AC 230 V - 3-AC 230 V - ELECTRIC MODELS ONLY
- SIDE RUNNERS

OPTIONAL - TO BE REQUESTED WHEN ORDERING OVEN

- **IPS051**: OPPOSITE HINGED DOOR
- **APDS**: DOUBLE RELEASE DOOR OPENING
- **SN**: EXTRA CHARGE FOR ENERGY SAVING SYSTEM CONNECTION - ELECTRIC MODELS ONLY
- **NPK**: CONFIGURATION FOR CONNECTION TO EXTRACTION HOOD
- **ISP464**: EXTRA CHARGE FOR PASTRY VERSION SHELF RACKS IGP464
- **CSA**: RETRACTABLE BUILT-IN 5 LITERS TANK - CAN BE USED IN THE LACK OF WATER CONNECTION FOR STEAM OR COMBI COOKINGS WITH A RANGE OF UP TO 60 MINUTES - NOT AVAILABLE WITH AUTOMATIC CLEANING SYSTEM

EXTRA ACCESSORIES THAT CAN BE INSTALLED FOLLOWING PURCHASE

- **KIPS051E**: KIT FOR OPPOSITE HINGED DOOR

ICET051E

- **ICLD:** HAND SHOWER WITH FITTINGS AND CONNECTIONS
- **IBAS051:** ANTI-INTRUSION BAR
- **ISR071E:** STAINLESS STEEL FLOOR STAND - FULL AISI 304
- **ISR071S:** STAINLESS STEEL FLOOR STAND FOR INSERTION OF THE BLAST CHILLER MOD. 050-051 - FULL AISI 304
- **NPT071:** SIDE RUNNERS - FIXED TO FLOOR STAND - FULL AISI 304
- **NPT064:** SIDE RUNNERS - FIXED TO FLOOR STAND - FULL AISI 304
- **IGP464:** PAIR OF SHELF RACKS - 600 X 400
- **ILV126:** PROOFERS WITH HUMIDIFIER AND DIGITAL PROGRAMMABLES CONTROLS - GLASS DOOR
- **NPF04:** FLANGED FEET KIT FOR FLOOR STANDS, FOR MARINE INSTALLATIONS
- **RP04:** CASTER KIT FOR FLOOR STANDS, 2 WITH BRAKE
- **IKKV51:** EXTRACTION HOOD WITH AIR-COOLED CONDENSER - ELECTRIC MODELS ONLY - AVAILABLE ONLY FOR PREARRANGED OVENS
- **CCE:** COLLECTOR FOR EXTERNAL CONNECTION - Ø 150 MM
- **KFP002:** FOOT FASTENER KIT
- **ICFX01:** FAT FILTER

CERTIFICATIONS



The data reported in this document is to be considered non-binding. The company reserves the right to make changes at any time, without prior notice

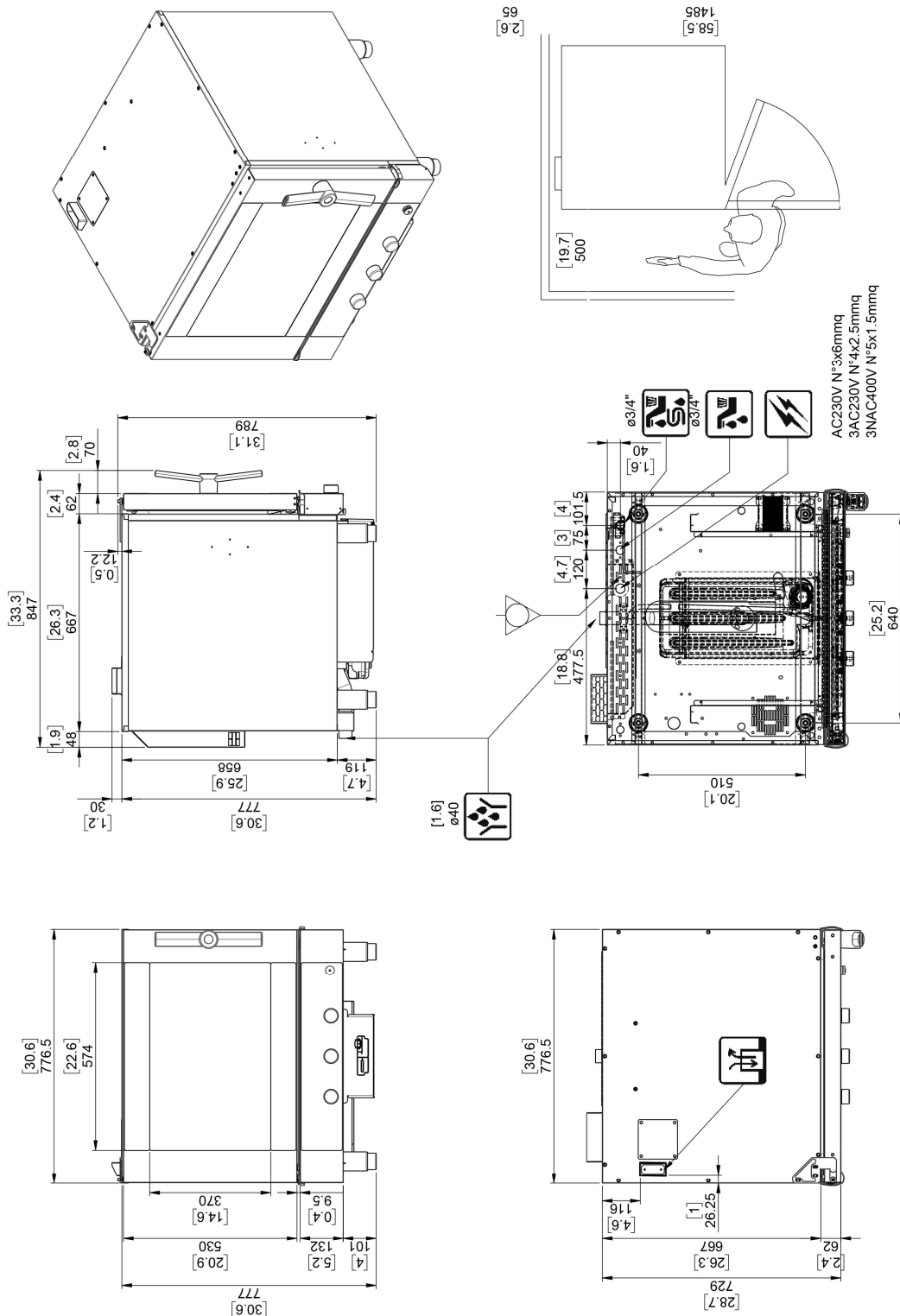

Dimensions: Millimeters [inches]